

Full-Range Position Transmitter with Digital Sensing

Power Supply Requirements

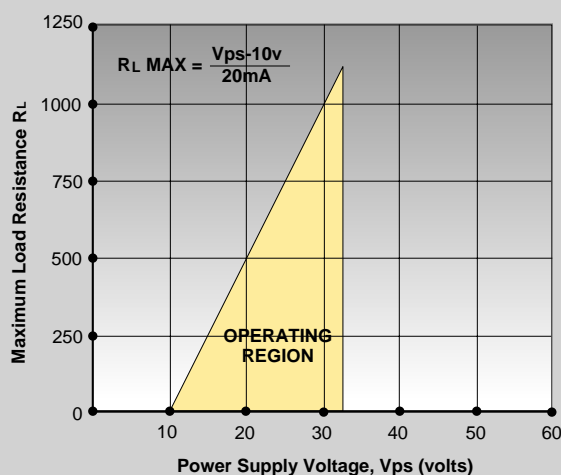

Spectrum DT™

Digital Position Transmitter

Westlock has merged absolute encoder sensing technology with loop-powered analog transmission to create the Spectrum DT™ full-range position monitor. The communication mode continues to be the standard 4-20 mA analog signal while actual sensing is achieved by a true digital sensor.

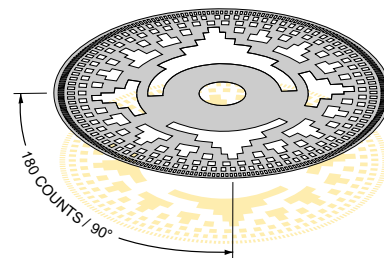

Key Performance Benefits

- Reference accuracy is three times that of traditional potentiometric analog sensors.
- Shifts due to environmental effects such as temperature are improved by a factor of three or more compared with traditional analog sensors.
- Greater repeatability and accuracy that digital control systems brought to the control room have now been extended into process measurement in the field.
- Non-contact means of position sensing yields higher accuracy over the life of the product.

True Digital Position Sensing

An absolute encoder is a position verification device which provides position information for each shaft location. The digital code is unique to each location. In absolute encoders, there are several concentric tracks, each with an independent light source. As light passes through a slot, a high state called "true 1" is created. When light does not pass, a low state known as "false 0" is created. Shaft position is identified by the pattern of 1's and 0's.

Loop-Powered 4-20 mA Transmission

The 4-20 mA analog signal, which has long been a useful method of interfacing sensors to remote computers, is the main standard for data transmission of the Spectrum DT.

The Spectrum DT Position Transmitter derives its operating power from the 4-20mA loop itself, with no need for an external power connection. This is a high-level signal not easily affected by outside noise. In addition to the advantages of standardization, reduced field wiring costs and immunity from most electrical noise, the 4-20 mA transmitter offers these benefits:

- Any number of signal receivers can be series-connected into the signal circuit without upsetting calibration.
- Multiple transmitters may share the same power supply.
- A 4-20mA signal is a "live zero" signal, which distinguishes a process condition (4mA) from an open circuit condition (0mA).
- No position loss on power down.
- Operates in electrically noisy environments.

Spectrum DT™

Digital Position Transmitter

Operating Description

The shaft encoder is an 8 bit device, utilizing gray code parallel outputs. Gray to binary conversion takes place before further signal processing. Data corresponding to shaft position is latched, and fed to a high quality digital to analog converter, with timing synchronized to encoder LED excitation. A precision, low drift voltage reference is utilized for the D/A converter DC source, as it is for the scaling and live zero circuitry which follows. Voltage to current conversion develops the true current sink output characteristic provided by the transmitter. Current sampling and feedback assure that a current which is truly representative of shaft position is generated.

The internal power supply is derived in total from the 4 to 20 mA signal loop. Stored energy from that power supply is delivered to the encoder LEDs for excitation on a pulsed basis for a period of several milliseconds approximately once every 20 milliseconds. In this manner, LED current excitation requirements in excess of 100 mA can readily be met despite the constraints imposed by 2 wire current loop operation. Operation of the data latch and D/A converter, as mentioned above, is synchronized to LED excitation.

DIMENSIONS (inches/mm)

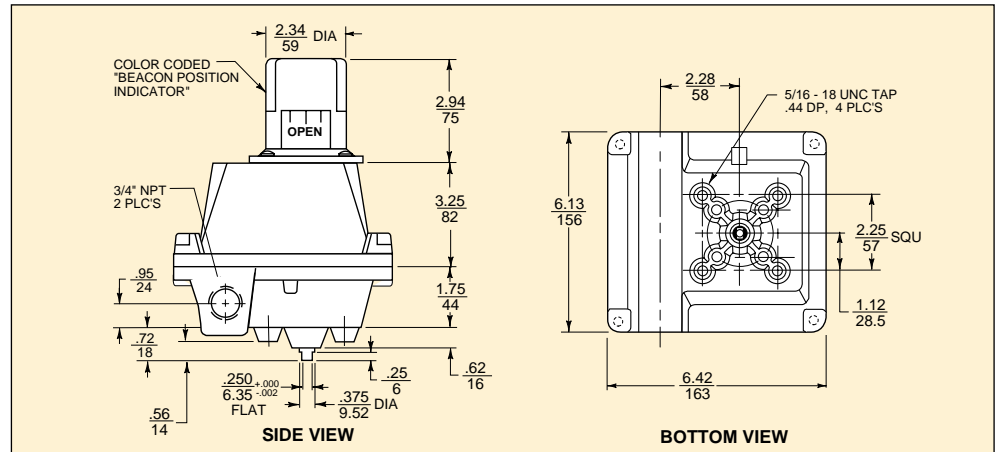

TECHNICAL SPECIFICATIONS

Transmitter type:	Angular position, intended primarily for control valve applications, damper applications, and similar uses.
Output:	4 to 20 milliamperes (2 wire), proportional to position. Position range is 90° (reversible) corresponding to nominal output current range.
Operating principle:	Absolute shaft encoder, non-contacting.
Electrical overrange capability:	90° of span under range of 4° and over range of 15°. For travel below range bottom, output current will limit at minimum of approximately 3.2 mA.
Mechanical overrange capability:	Infinite (shaft may be continuously rotated).
End of range wraparound:	Provided 180° away from range midpoint.
Terminal voltage req.	10 to 32 volts DC. Reverse polarity protected.
Temperature range:	-32°C to +85°C. Sunshade available for use when needed.
Temperature effect:	Less than 0.16%/°C referred to full scale.
Humidity range:	10% to 90%, non-condensing.
Terminal voltage effect:	Less than 0.1%, from 10 to 32 volts.
Linearity:	Within 0.5 least significant bit.
Output update rate:	Once per second.
Startup stabilization time:	6 seconds, nominal.
Resolution	0.7° 256 counts in 180°

ORDERING GUIDE

AREA CLASSIFICATIONS

NEMA 4, 4x, 7, 9
Class I, Groups C, D
Class II, Groups E, F, G,
Divisions 1 & 2

ENCLOSURE

Conduit Entries 2 - 3/4" NPT
Terminal Strip 8 contacts standard
16 contact available

APPROVALS / CERTIFICATION

UL (Underwriters Laboratories, Inc.)
CSA (Canadian Standards Association)

ENCLOSURE	BEACON™	3-WAY BEACON™	SOLENOID
<p>AccuTrak DT Transmitter</p>	STANDARD (Black & Yellow) BY	90° Rotation 	To Be Specified By Customer
	ANSI YELLOW (Inherently Hazardous) AY	90° Rotation 	
	ANSI GREEN (Liquid-Low Hazard) AG	90° Rotation 	
	ANSI BLUE (Gas-Low Hazard) AB	180° Rotation 	
	ANSI RED (Fire Quenching) AR	180° Rotation 	