

**Network Monitors with ModBus® Direct Interface Capability**

## Intellis® 7400

# ModBus® Direct Network Systems

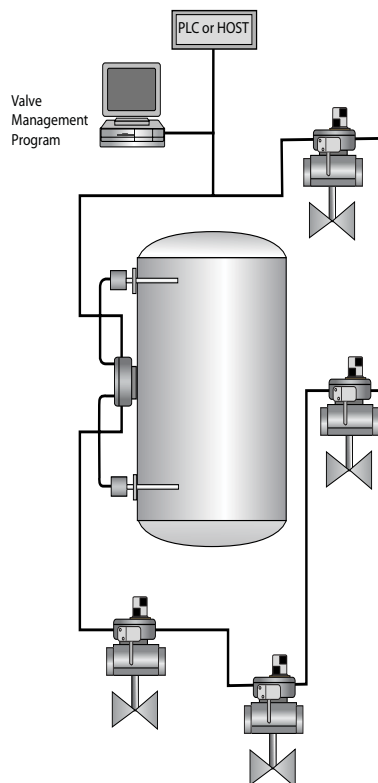

### MODBUS®

The Modbus® protocol is a messaging structure that was developed by Modicon in 1979 and is used to establish master-slave/client-server communication between intelligent devices. It is the most widely used network protocol in the industrial manufacturing environment and is supported by almost every PLC, DCS and operator interface (OI) company. The Westlock Modbus Direct Intellis I/O module utilizes the Modbus protocol to serially communicate with a DCS or PLC. The Modbus protocol establishes a common format for the layout and contents of all message fields. Operating commands, sent via Modbus, communicate directly from a controller, to a number of control valves connected, on a common data highway.

### Intellis® ModBus® Direct Overview

<b>Physical Media</b>	Twisted pair for communications, two wires for power
<b>Maximum Distance</b>	3000 ft.
<b>Maximum Network Monitors per System</b>	32/network
<b>Maximum I/O Points per System</b>	256/network plus optional 4-20 mA analog I/O per slave
<b>Current Consumption Per Network Monitor</b>	27 mA + 20mA/coil (25mA XP coil)
<b>Interface Capability</b>	All PLC's & DCS w/Modbus Port.
<b>Communications Method</b>	Master/slave with cyclic polling
<b>Error Checking</b>	CRC check
<b>Network Topology</b>	Zero drop
<b>Transmission Speed</b>	9.6 kbps & 19.2 kbps
<b>Redundancy</b>	No
<b>Valve Specific Diagnostics</b>	Yes

**WESTLOCK**  
Network Systems Group

Westlock reserves the right to change product designs and specifications without notice, and is not responsible for errors and omissions.

# ModBus® Direct

## How The System Operates

### Field Network

A field network consists of a group of Network Monitors interconnected with a common communications protocol. With the ModBus Direct Intellis System, I/O service and diagnostics are communicated over a local area field network.

### Network Monitor

Each Network Monitor is assigned a number from 0 to 31 which is called its address number. This number identifies one Network Monitor from all the other Network Monitors in the system.

### Network Modbus Port

Data is transferred serially in "select-check" form from the Network Monitor to the Modbus port in the PLC or DCS. 32 valves are polled by the Modbus master as I/O data are exchanged between the master and the field devices.

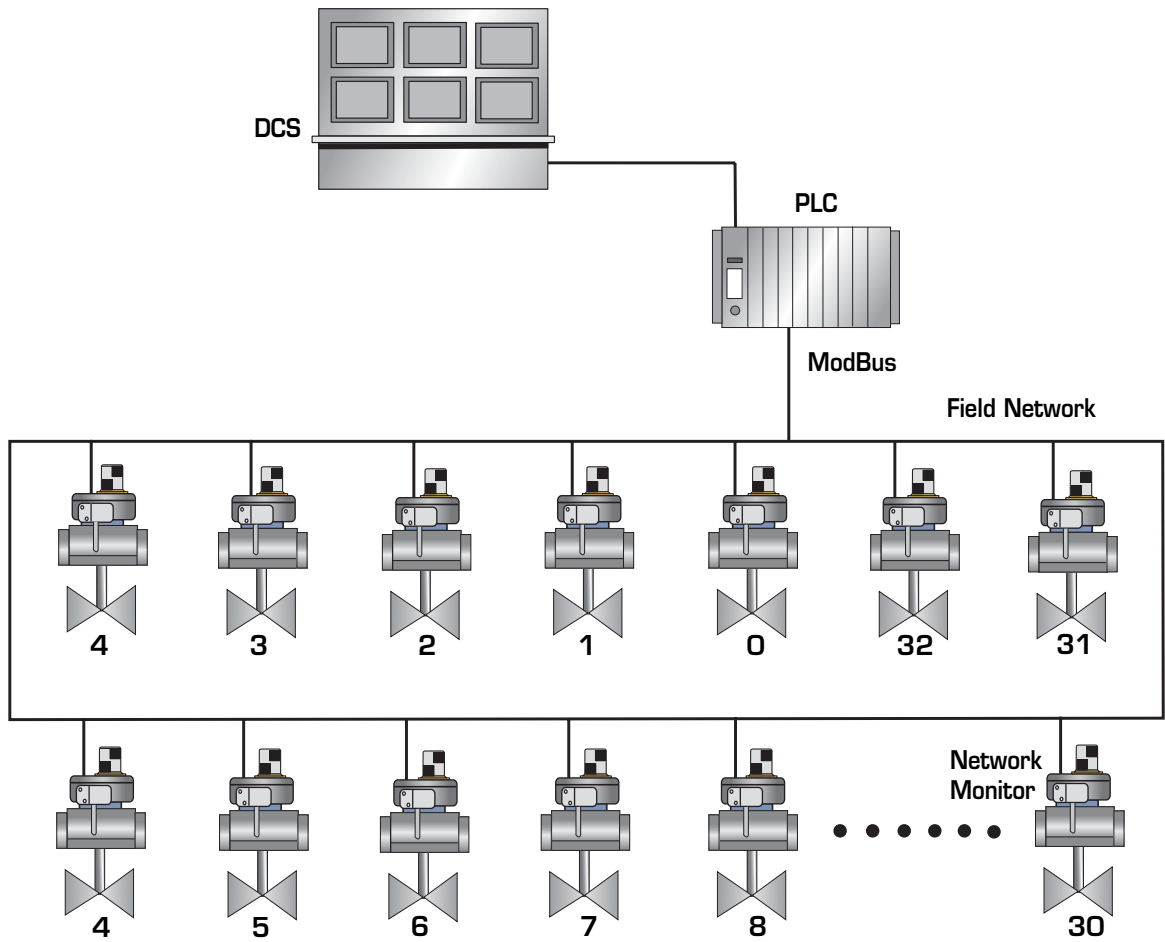

### Number of I/O points on a single network.

Because each network may connect up to 32 Network Monitors, the total number of programmable discrete I/O points would be 256 discrete I/O and 32 analog inputs per network.

## Intellis® 7400

# ModBus® Direct Network Systems

### NETWORK MONITORS

A ModBus® Direct Network System is established by integrating an OnBoard I/O module directly within the Westlock Network Monitor. Each I/O module has the capability to accept input/output signals from automated valves, position sensors, solenoid valves, emissions monitors and external devices (level alarms, temperature and pressure sensors, flow switches, etc.)

#### Automated Valve Network Monitor

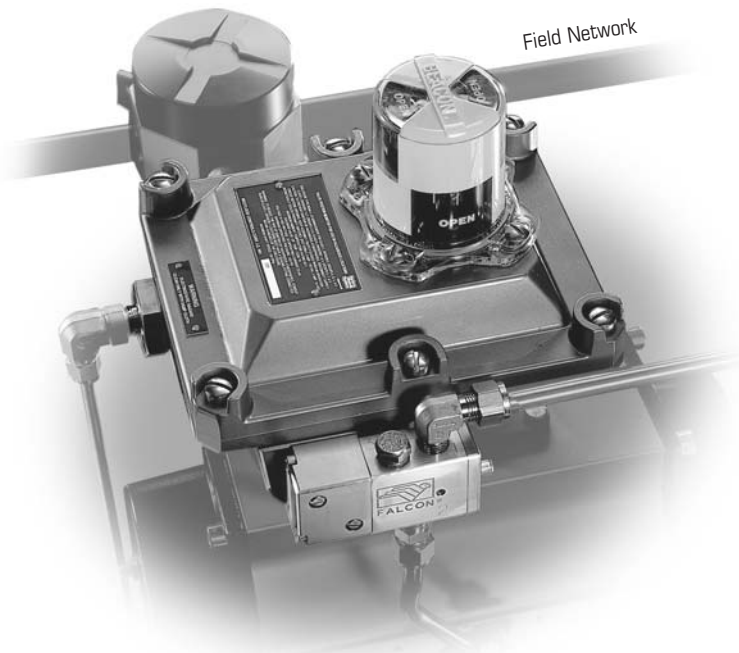

The Automated Valve Network Monitor couples directly to the pneumatic actuator. It houses three functional components; position sensors, low-power solenoid valve, and an OnBoard I/O module. The OnBoard I/O module is capable of accepting six input and two output devices.

#### ONBOARD I/O CARD

- INPUT 1:** Valve Position Sensor (open)
- INPUT 2:** Valve Position Sensor (closed)
- INPUT 3:** Temperature Monitor (internal electronics)
- INPUT 4:** External Device or  
Optional Pressure Monitor (supply air)
- INPUT 5:** External Device
- INPUT 6:** External Device

**ANALOG INPUT:** External Device

- OUTPUT 1:** Solenoid Valve (actuation control)
- OUTPUT 2:** Dual Coil Application or External Device

#### External Device Network Monitor



An External Device Network Monitor is available for control or monitoring of non-valve related devices (sensors, alarms, actuators, indicating lights, etc.).

Depending upon the process layout, a wide range of options exist. Standard units are supplied with protective diodes and optical isolation features. External Device Network Monitors are available in a **6 input/2 output** configuration. Power requirements for each external device are considered within the design parameters of the overall system.

## ModBus®

### Modbus Direct Communications

The Westlock Direct Intellis I/O module utilizes the Modbus protocol to serially communicate with a DCS or PLC. The Modbus protocol establishes a common format for the layout and contents of all message fields. Operating commands, sent via Modbus, communicate directly from a controller, to a number of control valves connected, on a common data highway, to the Modbus port.

#### Modbus Interface Transaction

A Modbus compatible controller (designated as Master) communicates with the Westlock Direct Intellis I/O modules (designated as Slaves) by a Master-Slave technique, in which only one device (the Master) can initiate transactions. The Intellis I/O module (Slave) responds by supplying the requested data to the Master, and by taking the action requested. A Master is capable of sending a message (called a 'query') to one specific Slave or to the entire group of Slaves (called a "broadcast"). A Slave will acknowledge the query that contains its individual slave address, by sending back

a message (called a 'response'). Responses are not returned if the Master sends the message to all the Slaves (broadcast). The Modbus protocol establishes a format for the Master's message which contains a slave (or broadcast) address, a function code defining the requested action, all data to be sent, and an error-checking field. The Slave response message, as defined by the Modbus protocol, contains the slave address, a function code confirming the action taken, all data to be returned, and an error-checking field. If a Slave detects an error in communications (incorrect stop/start bits, wrong parity or mismatch in error-checking field) it will not generate a response. If the Slave receives the communication correctly but is unable to perform the requested action, then an error message is sent back as a response to the Modbus Master.

At the physical layer the connection between the Master and Slaves utilizes an RS-485 connection consisting of a shielded, twisted pair of wires.

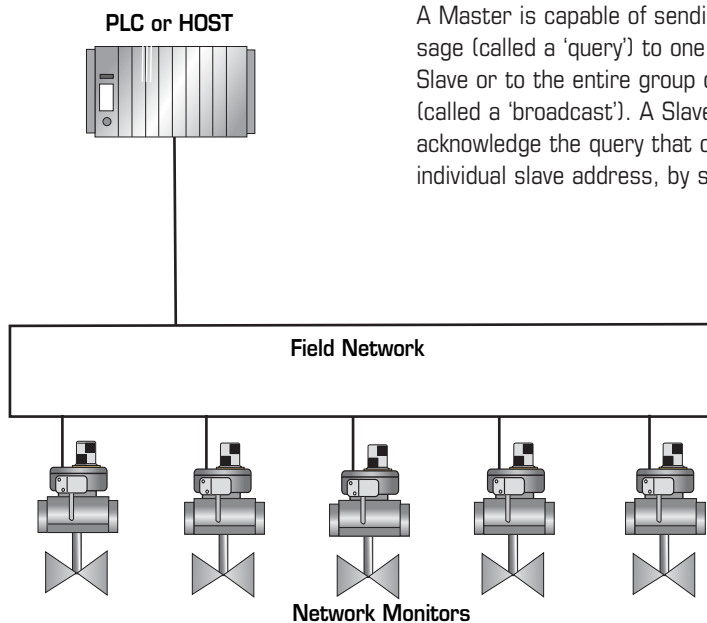

## WESTLOCK

### Westlock Controls Corp.

280 Midland Avenue  
Saddle Brook, NJ 07663  
201-794-7650  
Fax: 201-794-0913

### EUROPE

22 Chapman Way  
Royal Tunbridge Wells, Kent  
TN23EF England  
011-44-189-251-6277  
Fax: 011-44-189-251-6279

### SOUTH AMERICA

Westlock Equipamentos De  
Controles Ltda.  
Rua, Sao Paulo 291 - Alphaville  
Banueri, Sao Paulo  
SP 06464-130  
011-55-11-4191-0930  
Fax: 011-55-11-4191-0931

[www.westlockcontrols.com](http://www.westlockcontrols.com)